

FM0+120SD1NQ

1. Power supply selection (Note: * default setting)

POWER SOURCE

	CN23	CN28	CN30
DC 5V	1-2*	1-2*	1-2*
USB VBUS	1-2	1-2	2-3
JTAG V-supply	1-2	2-3	Open

VCC SELECTION

	CN32	CN35	CN37	CN33	CN34
3.3V	1-2*	1-2*	1-2*	1-2*	1-2*
5V	2-3	2-3	2-3	1-2	1-2

2. Switch, Jumper Pin Settings (Note: * default setting)

	FUNCTION	SETTING	ACTION
SW1	RESET SWITCH	PUSH ON	RESET
		PUSH OFF	NOT RESET
SW2	MD0	1-2	HIGH
		2-3*	LOW
SW3	MD1	1-2	HIGH
		2-3*	LOW
SW4	USB SELECTION	5-6 2-3	USB HOST
		4-5 1-2*	USB FUNC
SW5	WKUP LEVEL SWITCH	5-6 2-3	H ENABLE
		4-5 1-2*	L ENABLE
SW6	(NO MOUNT)	-	-
SW7	(OPTIONAL)	-	-
SW8	(OPTIONAL)	-	-
CN1	AVRH	1-2*	CONNECT TO AVCC
CN2	AVRL	1-2*	CONNECT TO AVSS
CN7	INITX	1-2*	CONNECT TO RESET SWITCH
		2-3	OPEN
CN8	SOT (UART TX)	1-2*	OPEN
		2-3	CONNECT TO RS TRANSCEIVER
		3-4	PULL-DOWN

CN9	MD0	1-2*	CONNECT TO MD0 SWITCH
		2-3	OPEN
CN11	SIN (UART RX)	1-2*	OPEN
		2-3	CONNECT TO RS TRANSCEIVER
CN12	MD1	1-2*	CONNECT TO MD1 SWITCH
		2-3	OPEN
CN13	UDP0 (USB D+)	1-2*	OPEN
		2-3	CONNECT TO USB CONNECTOR
CN15	UDM0 (USB D-)	1-2*	OPEN
		2-3	CONNECT TO USB CONNECTOR
CN16	P50	1-2*	OPEN
		2-3	CONNECT TO VBUS CONTROL IC FLG
CN17	P51	1-2*	OPEN
		2-3	CONNECT TO VBUS CONTROL IC EN
CN18	P0A	1-2*	OPEN
		2-3	CONNECT TO USB D+ PULL-UP CONTROL
CN20	P60(USB CONN. DET.)	1-2*	OPEN
		2-3	CONNECT TO USB VBUS
CN21	OPTION CONNECTOR	1-2*	DO NOT USE WKUP SW (SW6)
		2-3	USE WKUP SW (SW6)
CN22	TEST CONNECTOR	1-2*	DO NOT USE USB
		2-3	USE USB
CN24	SWCLK	1-2*	OPEN
		2-3	PULL-DOWN
		3-4	PULL-UP
CN25	SWDIO	1-2*	OPEN
		2-3	PULL-UP
CN31	VREGCTL	1-2*	OPEN
		2-3	CONNECT TO VREGCTL

Revision history:
2014/11/25 Initial revision

The contents of this document are subject to change without notice.

The information, such as descriptions of function and application circuit examples, in this document are presented solely for the purpose of reference to show examples of operations and uses of Spansion Inc. and other vendors device; TOKYO ELETECH and Spansion Inc. do not warrant proper operation of the device with respect to use based on such information. When you develop equipment incorporating the device based on such information, you must assume any responsibility arising out of such use of the information. TOKYO ELETECH and Spansion Inc. assume no liability for any damages whatsoever arising out of the use of the information.

Any information in this document, including descriptions of function and schematic diagrams, shall not be construed as license of the use or exercise of any intellectual property right, such as patent right or copyright, or any other right of TOKYO ELETECH or any other right of Spansion Inc. or any third party or do TOKYO ELETECH and Spansion Inc. warrant non-infringement of any third-party's intellectual property right or other right by using such information. TOKYO ELETECH and Spansion Inc. assume no liability for any infringement of the intellectual property rights or other rights of third parties which would result from the use of information contained herein.

The products described in this document are designed, developed and manufactured as contemplated for general use, including without limitation, ordinary industrial use, general office use, personal use, and household use, but are not designed, developed and manufactured as contemplated (1) for use accompanying fatal risks or dangers that, unless extremely high safety is secured, could have a serious effect to the public, and could lead directly to death, personal injury, severe physical damage or other loss (i.e., nuclear reaction control in nuclear facility, aircraft flight control, air traffic control, mass transport control, medical life support system, missile launch control in weapon system), or (2) for use requiring extremely high reliability (i.e., submersible repeater and artificial satellite). Note that TOKYO ELETECH and Spansion Inc. will not be liable against you and/or any third party for any claims or damages arising in connection with above-mentioned uses of the products.

Any semiconductor devices have an inherent chance of failure. You must protect against injury, damage or loss from such failures by incorporating safety design measures into your facility and equipment such as redundancy, fire protection, and prevention of over-current levels and other abnormal operating conditions.

Exportation/release of any products described in this document may require necessary procedures in accordance with the regulations of the Foreign Exchange and Foreign Trade Control Law of Japan and/or US export control laws.

The company names and brand names herein are the trademarks or registered trademarks of their respective owners.

The following precautions apply to the product described in this manual.

Before moving the product, be sure to turn off all the power supplies and unplug the cables. Watch your step when carrying the product. Do not use the product in an unstable location such as a place exposed to strong vibration or a sloping surface.

Do not place anything on the product or expose the product to physical shocks. Do not carry the product after the power has been turned on. Doing so may cause a malfunction due to overloading or shock.

Since the product contains many electronic components, keep it away from direct sunlight, high temperature, and high humidity to prevent condensation. Do not use or store the product where it is exposed to much dust or a strong magnetic or electric field for an extended period of time. Inappropriate operating or storage environments may cause a fault.

Use the product within the ranges given in the specifications. Operation over the specified ranges may cause a fault.

To prevent electrostatic breakdown, do not let your finger or other object come into contact with the metal parts of any of the connectors. Before handling the product, touch a metal object (such as a door knob) to discharge any static electricity from your body.

Always turn the power off before connecting or disconnecting any cables from the product. When unplugging a cable, unplug the cable by holding the connector part without pulling on the cable itself. Pulling the cable itself or bending it may expose or disconnect the cable core, resulting in a fault.

It is recommended that it be stored in the original packaging. Transporting the product may cause a damage or fault. Therefore, keep the packaging materials and use them when re-shipping the product.

FM0+120SD1NQ (FIGURE EXAMPLE BELOW)

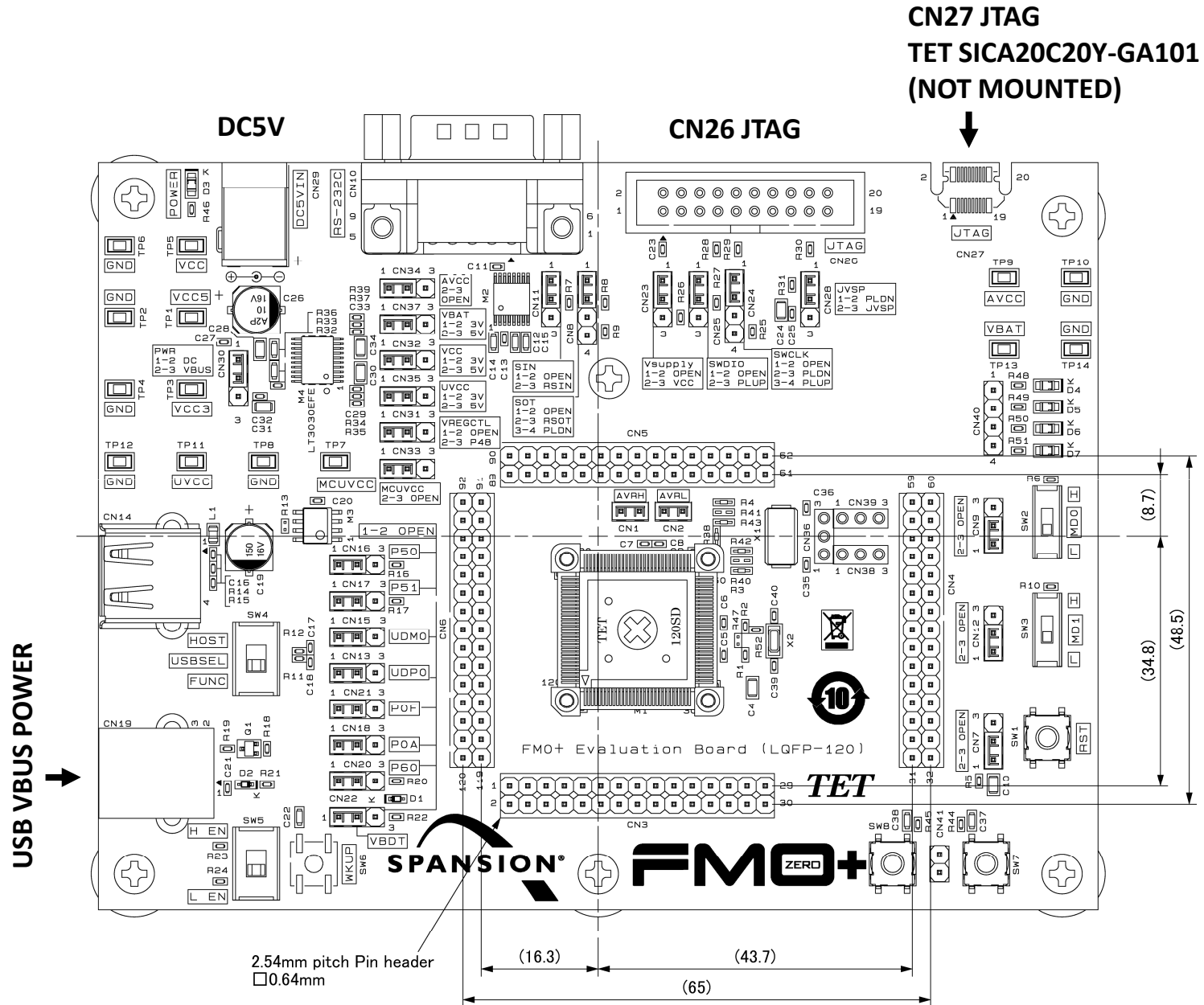

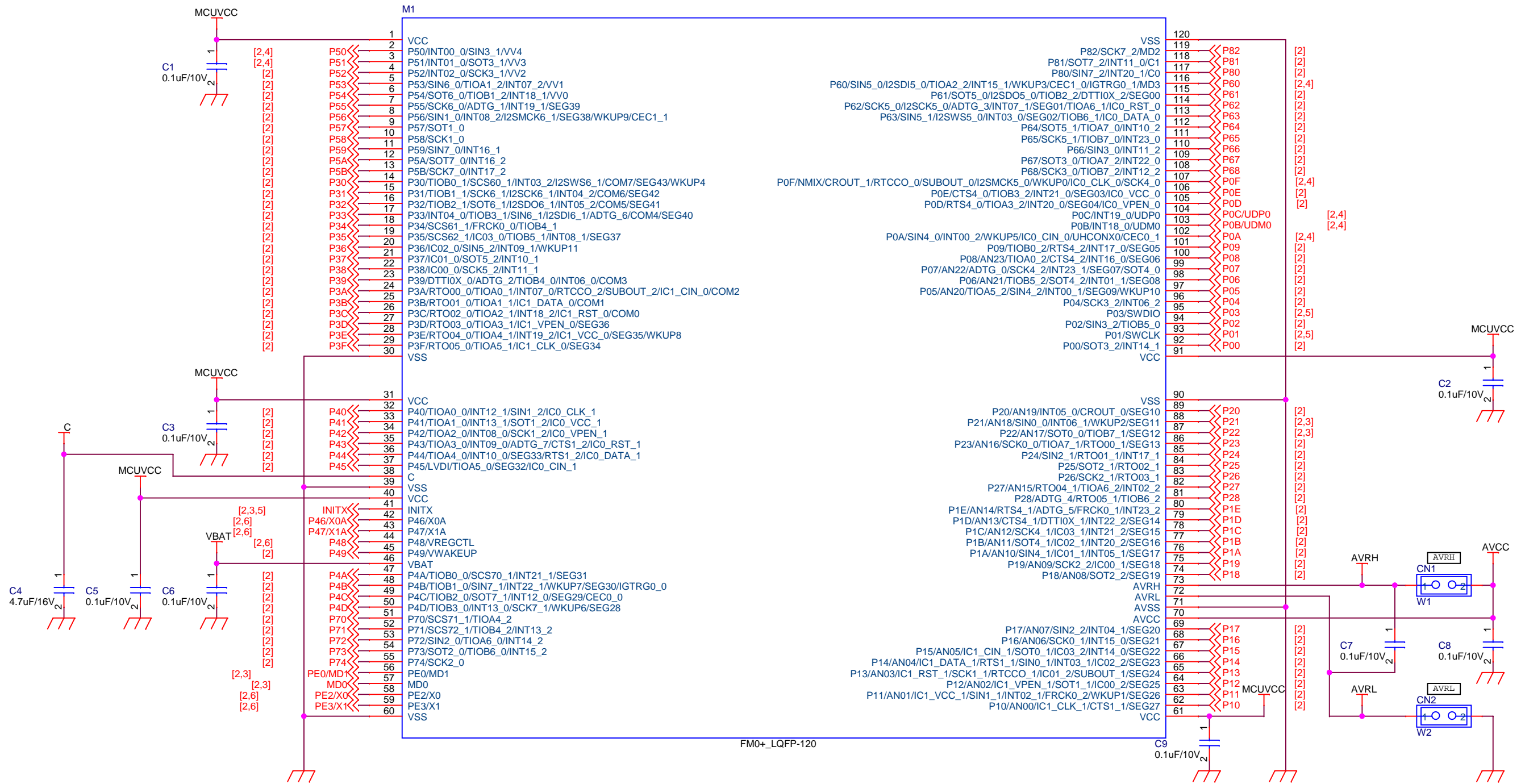

						Title			
						FM0+ Evaluation Board (LQFP-120)			
						MCU or SOCKET			
						Draw.No.			
Ed.	Date	Desig.	Check	Appr.	Description				
Desig.			Check	Appr.					
						Spansion Inc.		Sheet	1 / 6

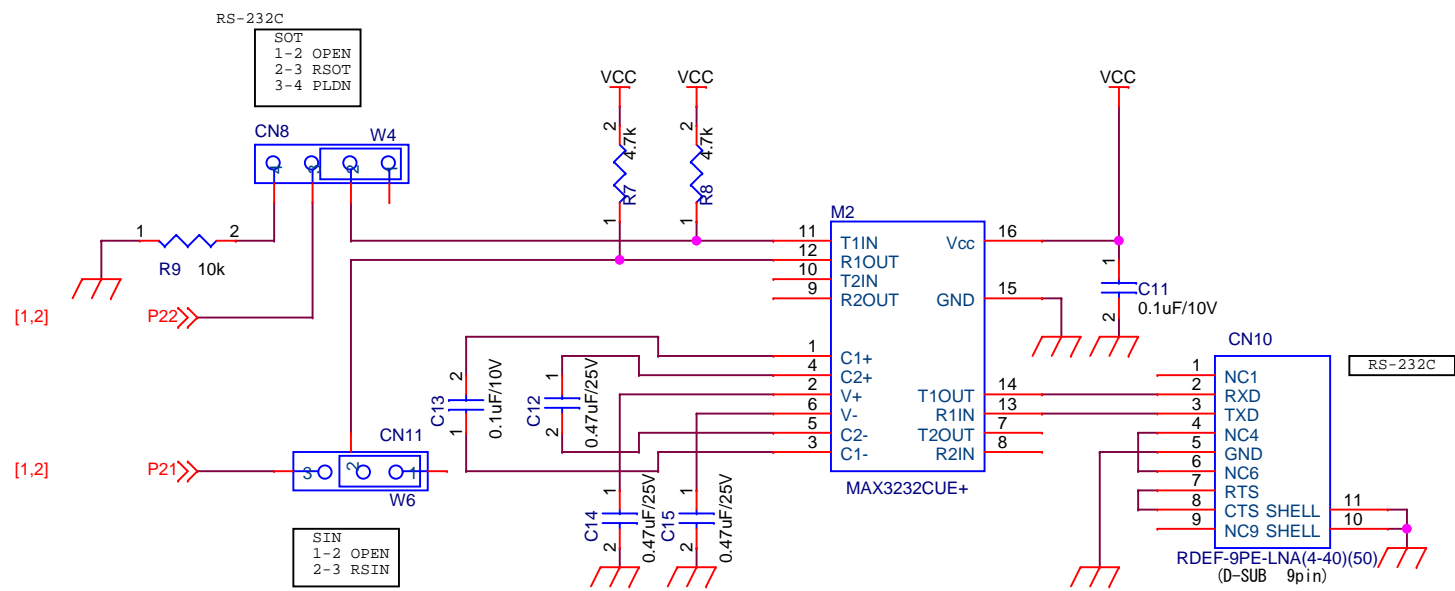
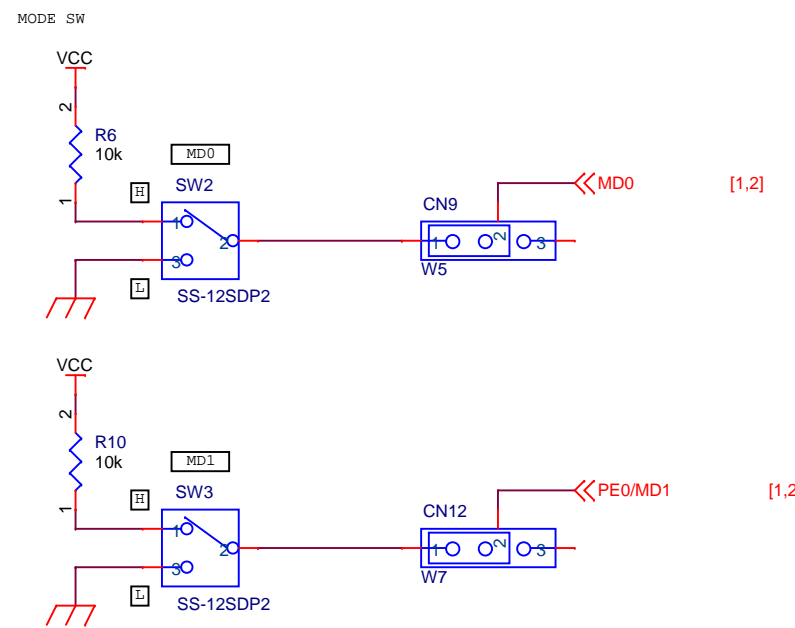
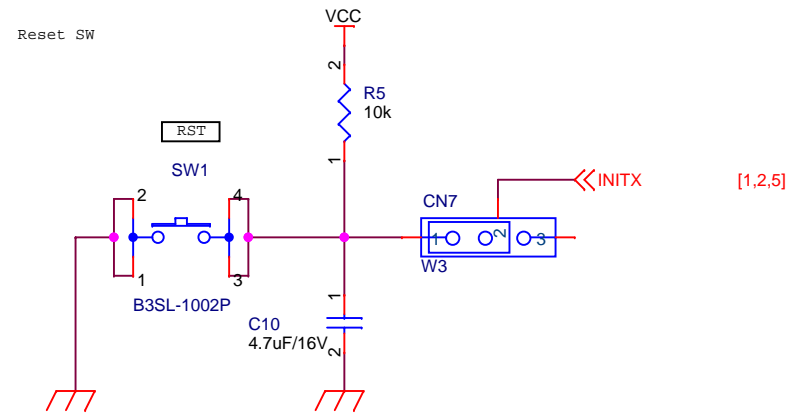

						Title			
						FMO+ Evaluation Board (LQFP-120)			
						MODE, RESET, RS232C			
						Draw.No.			
Ed.	Date	Desig.	Check	Appr.	Description				
Desig.			Check	Appr.					
						Spansion Inc.		Sheet	3 / 6

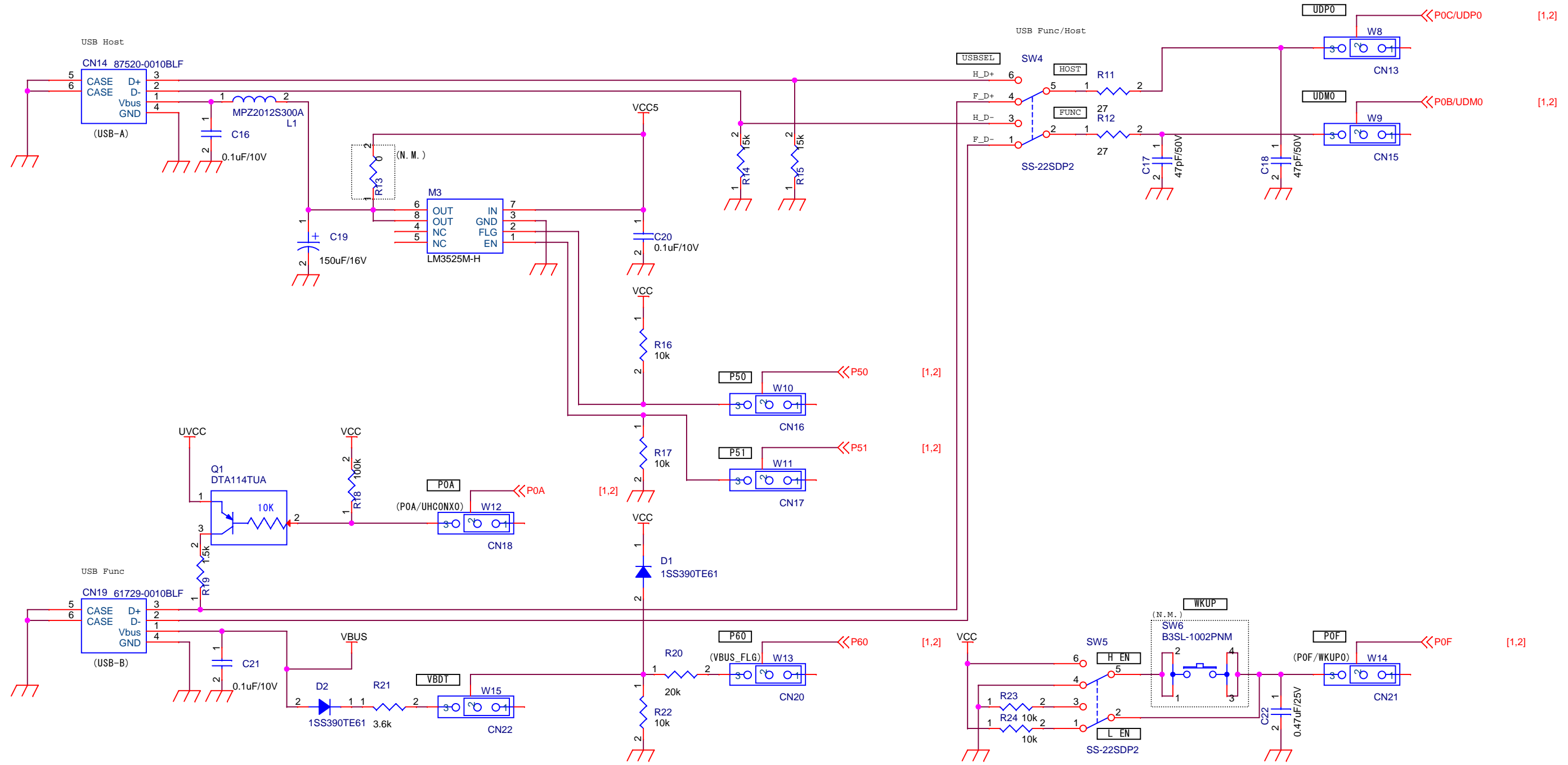

					Title	
					FM0+ Evaluation Board (LQFP-120)	
					USB	
					Draw.No.	
Ed.	Date	Desig.	Check	Appr.	Description	
Desig.				Check	Appr.	
					Spansion Inc. Sheet 4 / 6	

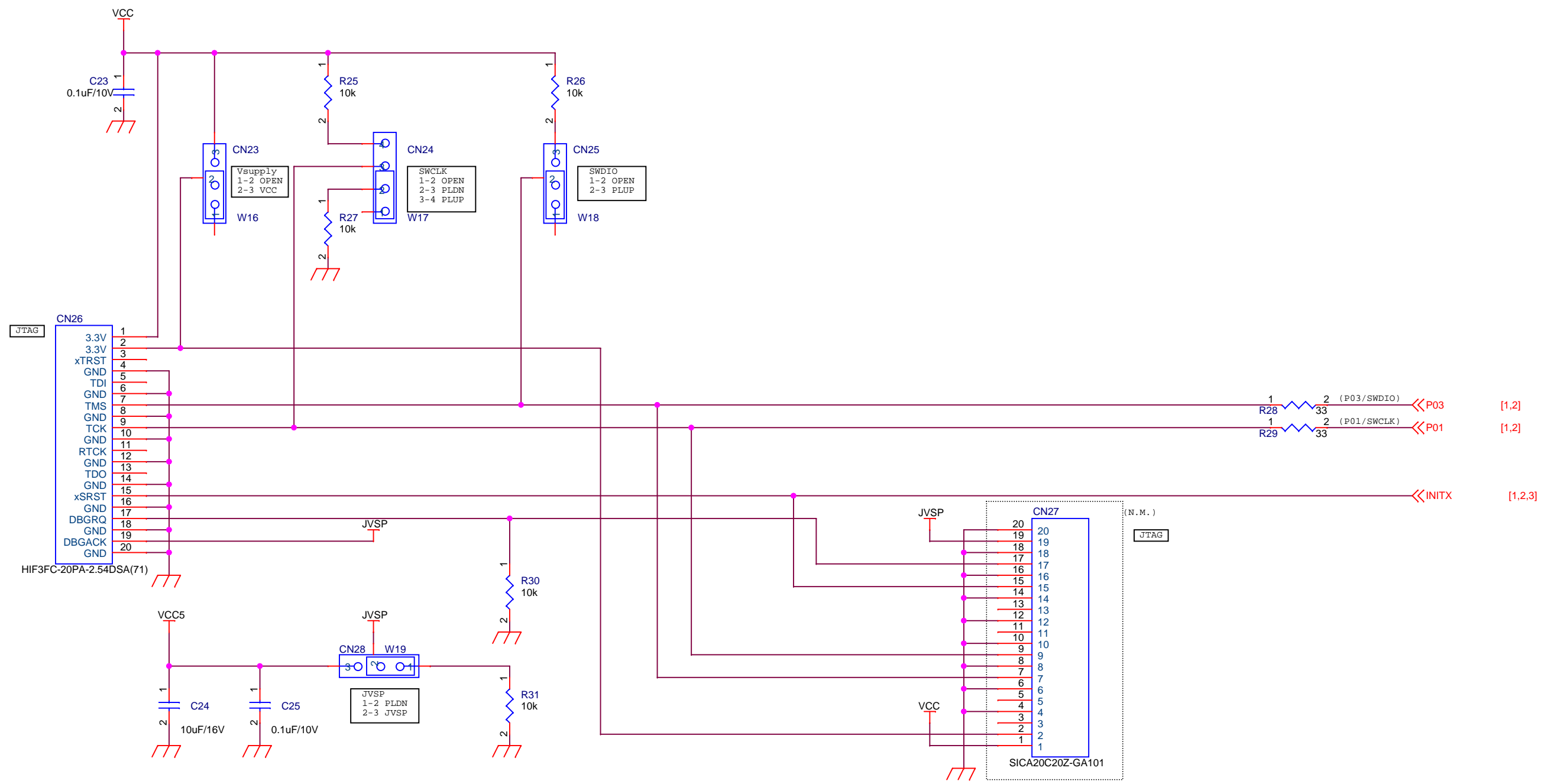

					Title	
					FMO+ Evaluation Board (LQFP-120)	
					JTAG	
					Draw.No.	
Ed.	Date	Desig.	Check	Appr.	Description	
Desig.			Check	Appr.		
					Spansion Inc.	Sheet 5 / 6

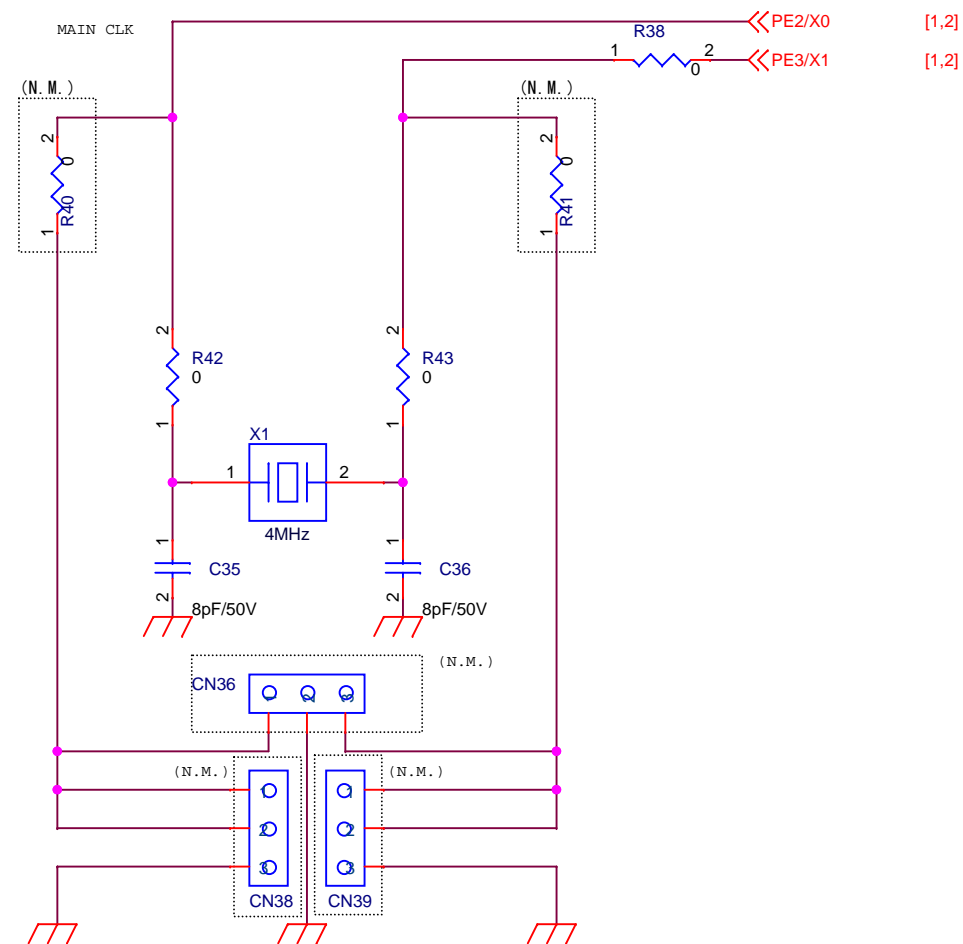
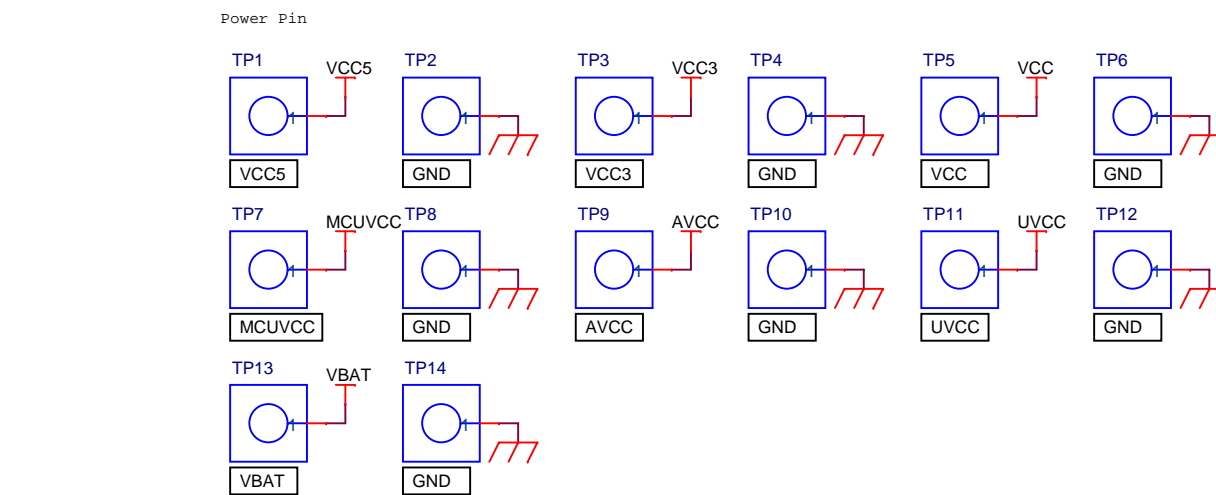
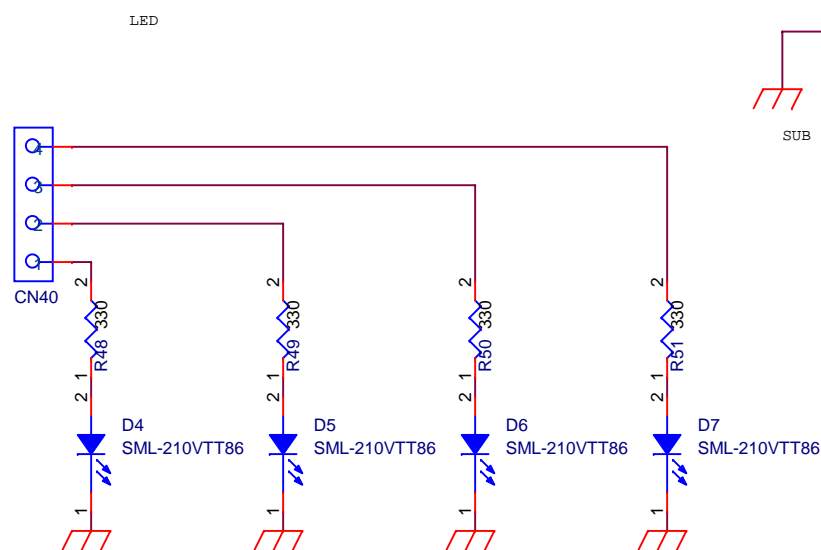
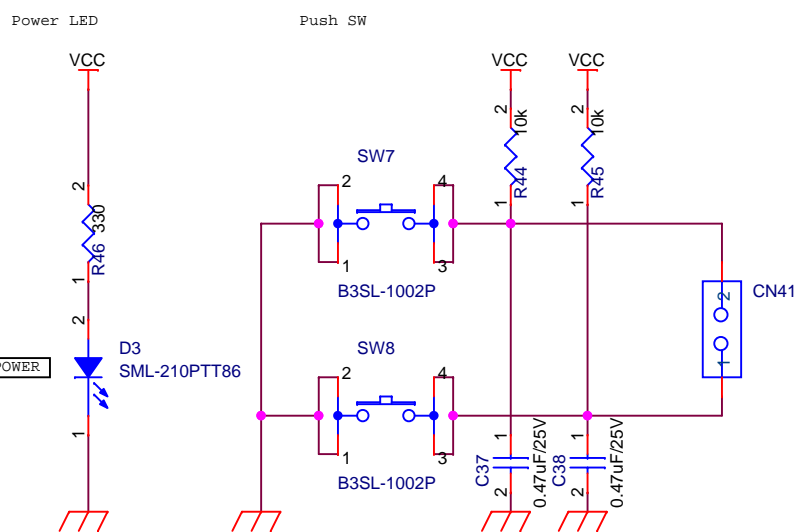
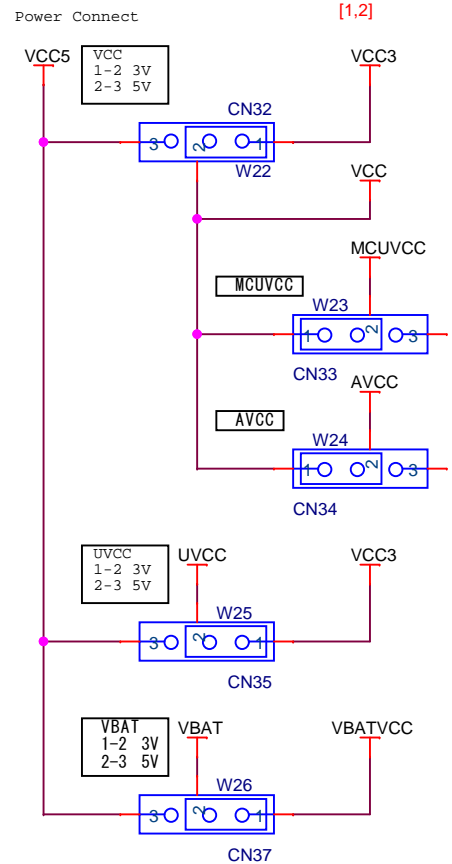
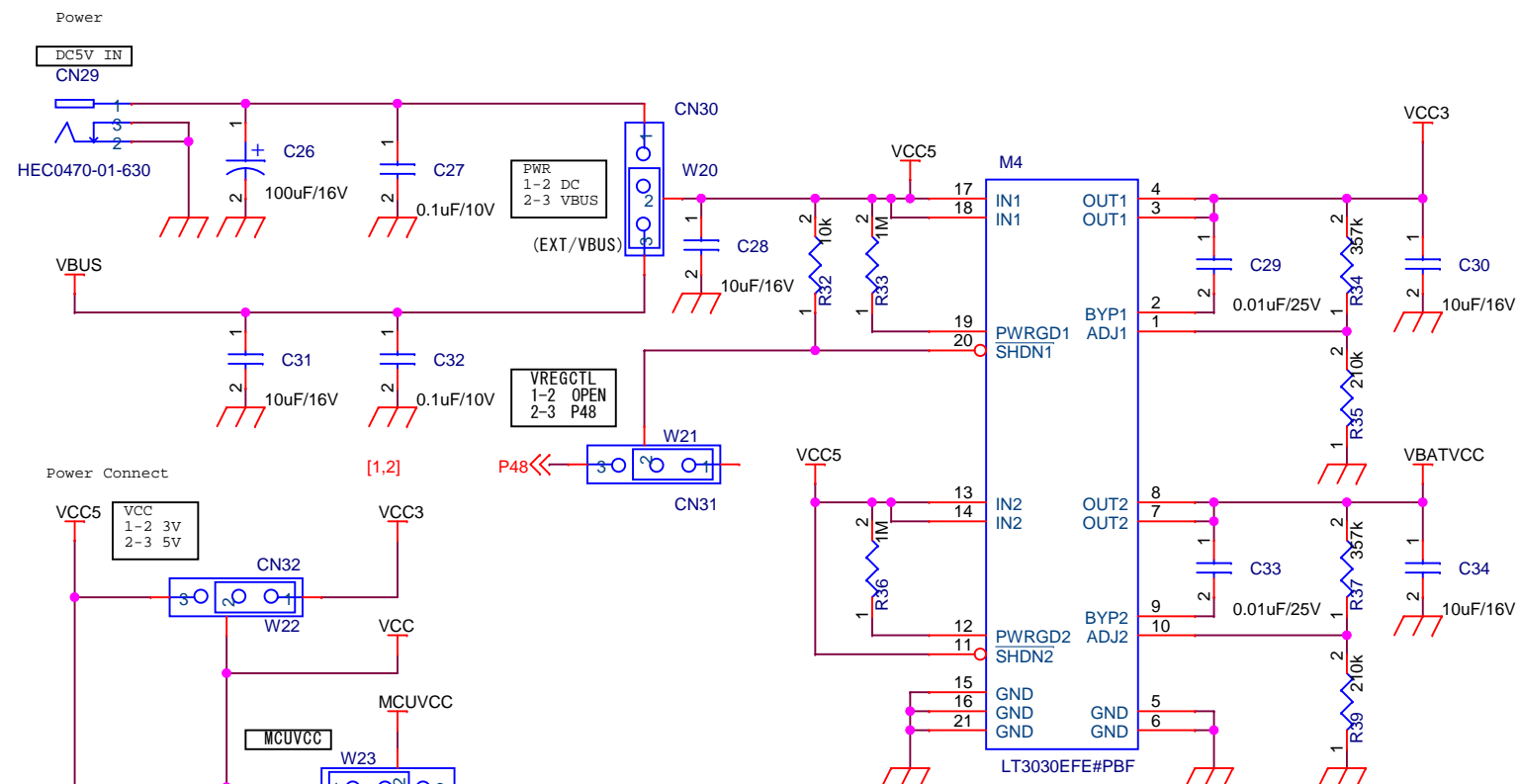

					Title	
					FMO+ Evaluation Board (LQFP-120)	
					POWER, LED, SWITCH, CLOCK	
					Draw.No.	
Ed.	Date	Desig.	Check	Appr.	Description	
Desig.			Check	Appr.		
					Spansion Inc.	Sheet 6 / 6

中華人民共和國「電子情報製品污染防止管理弁法」の対応

Compliance with Administration on the Control of Pollution Caused by Electronic Information Products of the People's Republic of China

电子信息产品污染控制管理办法（第 39 号）



这标记是按照 2006 年 2 月 28 日公布的[电子信息产品污染控制管理办法]以及 SJ/T11364-2006[电子信息产品污染控制标识要求]在中国销售的电子信息产品的环保使用期限。如遵守关于这产品的安全或使用上的注意，在这期限内（从生产日期起算）不会因产品中的有害物质漏到外部，或发生突然变异，而引起环境污染和对人体或财产的重大影响。

产品中有毒有害物质或元素的名称及含量

部件名称	有毒有害物质或元素					
	铅 (Pb)	汞 (Hg)	镉 (Cd)	六价铬 (Cr(VI))	多溴联苯 (PBB)	多溴二苯醚 (PBDE)
印刷线路板	×	○	○	○	○	○

○：表示该有毒有害物质在该部件所有均质材料中的含量均在 SJ/T11363-2006 规定的限量要求以下。
 ×：表示该有毒有害物质至少在该部件的某一均质材料中的含量超出 SJ/T11363-2006 规定的限量要求。